

# REGIONAL GROUP NEWS



Our December meeting was held in conjunction with our annual Christmas Banquet held at the Country House in Bristol, Virginia.

Max reported that all trophies for the Eastern National Meet have been sold and about half of the money collected for them. Members were urged to collect the remainder of the money by January. Max then introduced the new club officers for 1978. Max had some nice comments to the members for their efforts in making the first year a tremendous success for the First Tennessee Regional Group.

Max was presented a plaque by Don Wolfe on behalf of the membership for a job well done.

Special guests were Gary Goddard and Dwight Walls. Gary informed the club members of the new National Officers and of the National's plans for participating in helping to make the Eastern National Meet a success. Enthusiasm for this forthcoming event is growing across a wide geographical area. The Ramada Inn has already received quite a few reservations. Gary and Dwight had been briefed earlier in the day by club officers on progress to date and taken on a tour of the show site, headquarters and the Kingsport area in general.

Gary presented the First Tennessee Regional Group with a plaque reflecting Charter Membership in the Mustang Club of America.

Our banquet was attended by about 75 people. The variety and quality of food was excellent. The evening was finalized with members, families and guests participating in bingo amid much shop talk.

Our next regular meeting will be 7:00 p.m. January 26th at Anderson Ford.

Don Cox  
Secretary

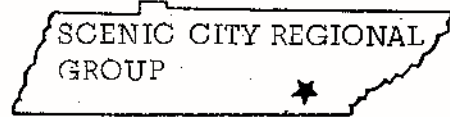

Anyone in the Scenic City area (Chattanooga) interested in joining our group, please contact:

John Henderson  
5661 Grayshore Lane  
Hixson, Tennessee 37343  
(615) 875-6991

FLORIDA  
REGIONAL  
GROUP



The Florida Regional Group will hold its next meeting on Sunday, March 12th in Tampa at Lowery Park. Look for complete details in the February Newsletter.

Larry Dobbs  
President

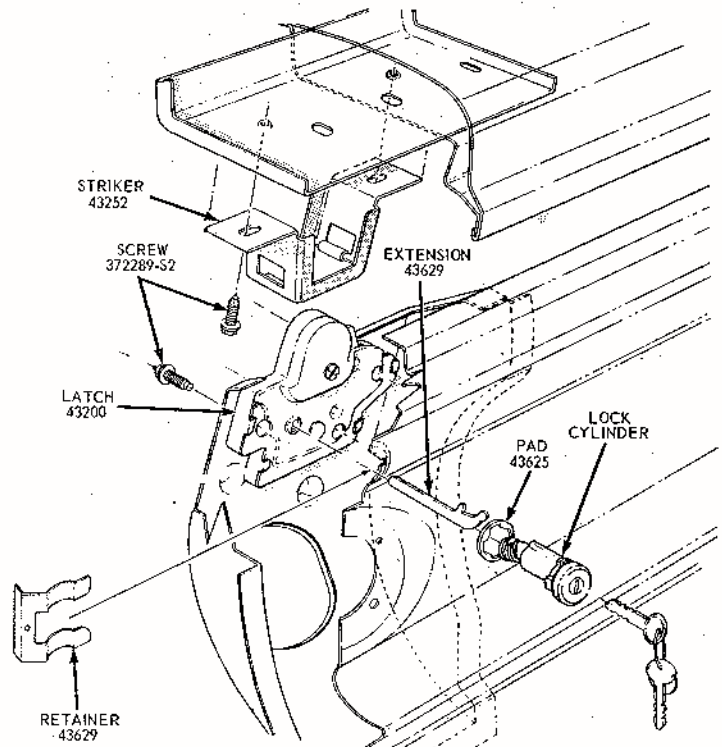

1969 MUSTANG LUGGAGE COMPARTMENT LATCH MECHANISM.....