

# MUSTANG DEPOT

WWW.MUSTANGDEPOT.COM



## MILD TO WILD 1965-2011 PARTS, ACCESSORIES AND INSTALLATION



**(702) 262-0011**

**2510 E. SUNSET ROAD #3, LAS VEGAS, NV 89120**

Not affiliated with Ford Motor Company

# '64-73 MUSTANG BOLT-IN IFS

ALSO FITS: COMET, COUGAR, FAIRLANE, FALCON, MAVRICK, MONTEGO, RANCHERO & TORINO

IT BOLTS TO STOCK FACTORY HOLES AND CAN BE INSTALLED IN A WEEKEND AT HOME WITH BASIC HAND TOOLS AND A DRILL MOTOR. Simply drill 8 holes and bolt it together. Engineered for superior handling, stopping and steering. The caster-and-camber weight is loaded onto the frame, not the inner fender panel.

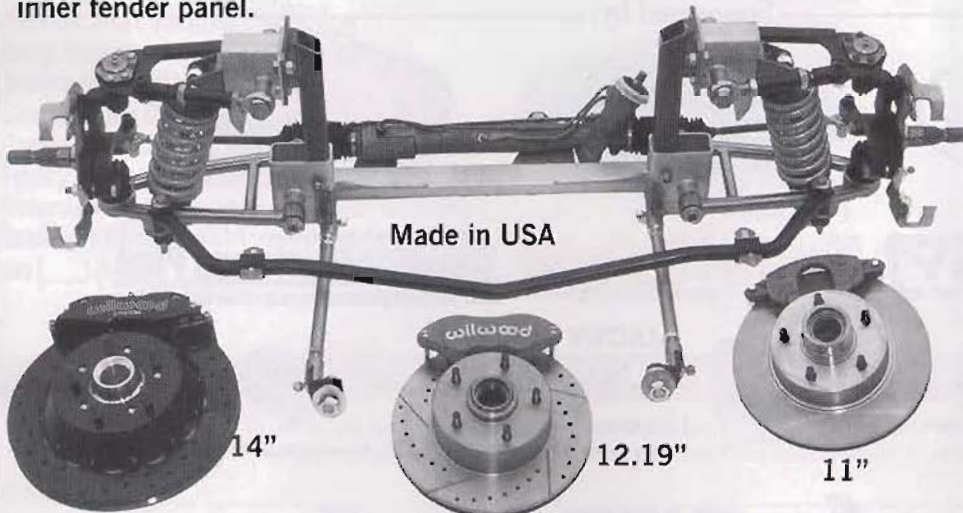

Made in USA

There is no need for tower supports. The rear steer crossmember that holds the rack sits above the bottom of the oil pan.

**THE STANDARD PACKAGE INCLUDES** our adjustable stance upper towers, power R&P, 11" disc brakes (with optional 12.19" or 14"), aluminum coil-over shocks, 1" diameter antisway bar and tubular a-arms (not Mustang II). All parts available separately.

www.jimmeyerracing.com \* E-mail: jim@jimmeyerracing.com

Tech Line: 541-994-7717  
Order Line: 1-800-824-1752  
2795 S.E. 23rd  
Lincoln City, OR 97367

**JimMeyer** Racing products inc